



v1.17



## Operating Manual

### Hyperion 924IPS

Short-Range DC Bar



# Contents

Introduction	3
Unpacking and Inspection	4
Contents	4
Options	4
Features of Hyperion 924IPS	5
Installation	8
Operation	12
Maintenance	13
Fault Finding	15
Troubleshooting	17
Repairs and Warranty	18
UL Approval	18
CE Approval	18
Technical Characteristics	19
Health and Safety	19
Technical Drawing	20

Products shown in this document may be covered by one or more patents, patents applied for and/or registered designs and/or trade marks. For further information please refer to our Head Office or visit [www.meech.com](http://www.meech.com).



# Introduction

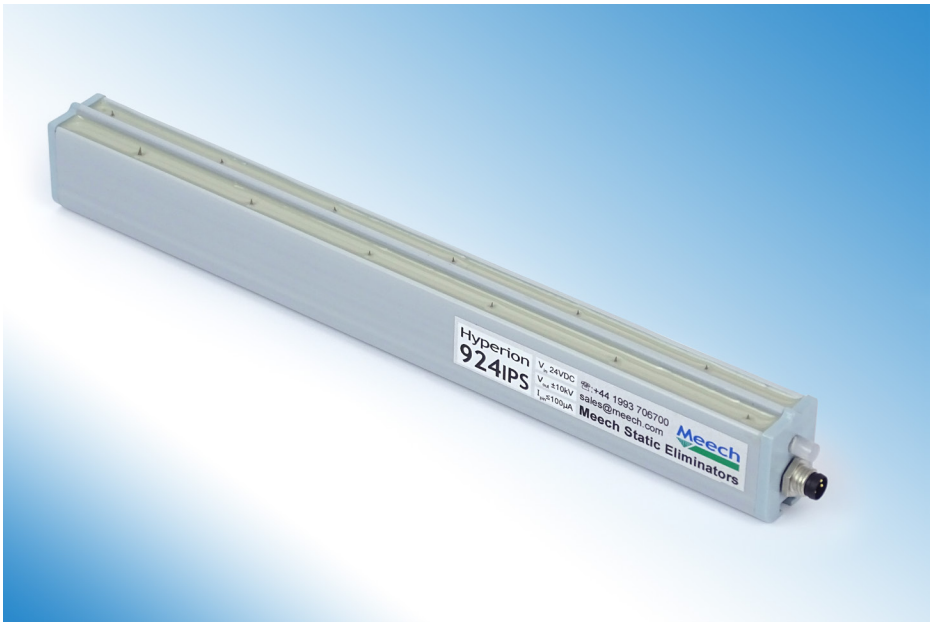

The Hyperion 924 IPS is a compact pulsed DC ionising bar. It is used to control static electric charges in short range applications (20-150mm). An integral 7.5kV pulsed DC power supply allows for easy installation on printing, converting and packaging machinery. Requiring only a 24V DC supply, the 924 IPS removes the need to route high-voltage cabling through the machine.

In most installations the default settings of the bar will provide exceptional static control. The local LED indicator shows the operational status of the bar and advises when the bar requires cleaning.

Demanding installations can take advantage of the adjustable output of the 924 IPS. Using the optional Hyperion BarMaster remote programmer, the frequency, balance and voltage output can be optimised to suit the application. Additionally, the Ion Current alarm setting can be changed to guarantee the required performance levels on critical processes.

The Hyperion BarMaster remote programmer is available for purchase from the Meech network: Visit [www.meech.com](http://www.meech.com) to find your nearest Meech office or distributor for further product information.

# Unpacking And Inspection

Your Hyperion 924IPS bar was carefully packed at the factory in a container designed to protect it from accidental damage. Nevertheless, we recommend careful examination of the carton and contents for any damage.

If damage is evident, do not destroy the carton or packing material and immediately notify the carrier of a possible damage claim. Shipping claims must be made by the consignee to the delivering carrier.

## Contents:

### Standard



924IPS Bar



Mounting Kit

### Options



Power Cable - 4 Pin M8 (straight or 90° elbow)  
Available in 2,3,5 and 10M lengths.



24V DC Supply & IEC cable



BarMaster remote programmer.  
Allows optimisation of the output of the 924IPS

# Features and Benefits of Hyperion 924IPS

## Low voltage wiring and Integrated Power Supply



The 924IPS is powered by 24V DC via a 4-pin M8 Connector.

## Shockless Emitters

The Titanium emitter pins on the 924IPS are resistively coupled to the high voltage supply. This avoids sparking and operator shocks.

## Sealed Construction

IP66 construction allows the bar to be mounted in areas subject to occasional wash-down or spillage. If the bar does become wet it must be thoroughly dried before being powered-up.

## Clean Pin Alert LED



The local LED illuminates constant green to indicate that the bar is on and working correctly. Red flashing LED shows that bar is dirty and needs cleaning. Solid red illumination indicates a fault with the high voltage output.

- Green constant – OK
- Green flashing – BarMaster remote programmer connected
- Red flashing - Cleaning required
- Red constant - Fault

## Clean Pin Alert and Fault Output

An output signal indicates when the bar needs cleaning or when a fault has been detected. The signal is 0V/24V output on pin 2. By default: Bar OK = 24V, Bar needs cleaning (or fault detected) = 0V. If required the signal can be inverted to give OK = 0V, Cleaning Required = 24V using a Barmaster Remote Programmer



## Divider

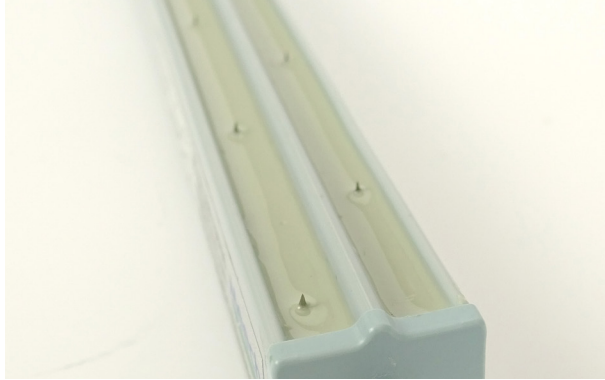

The 924IPS is designed to operate in dirty, factory environments. To maximise the interval between cleaning the bar features a divider to increase the surface tracking distance between the two rows of high voltage pins. It is important to clean this area during cleaning operations.

## T-Slot



The bar is mounted using the T-Slot at the rear of the bar. M4 T-bolts supplied with the bar maybe positioned to suit convenient mounting points.

# Installation

## Mechanical Installation

The 924 is a short to mid-range bar. Dependent on the application, the bar will be mounted between 20mm and 150mm from the target surface.

The bar should be mounted securely, using all the M4 T-bolts provided with the bar.

Correct positioning of the bar is vital for effective static control. There must be no metallic objects or obstruction between the bar and the material. The diagram shows the area that should be kept clear.

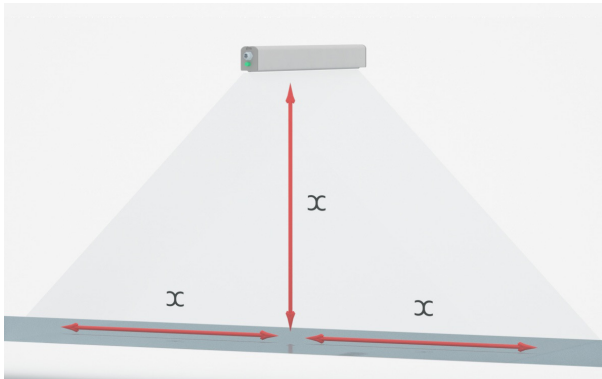

Where  $\chi$  lengths are equal.

When installed at short range over a web or sheet, the bars must be positioned away from surfaces and rollers, as shown in the following diagrams.

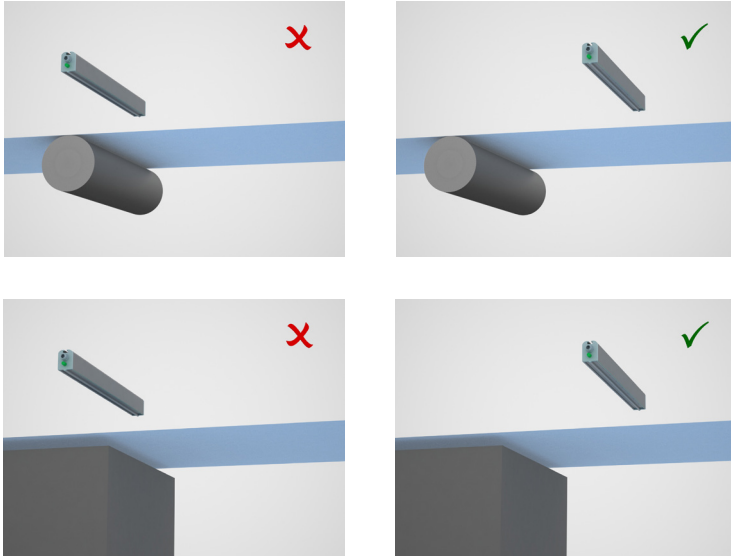

Your Meech distributor will be able to assist with questions regarding positioning of your equipment.

## Electrical Installation

### WARNING

The 924IPS requires a grounded 24V DC supply. The 0V line **must** be connected to ground. Failure to do so, will result in damage to the bar or the 24V supply and will void the warranty.

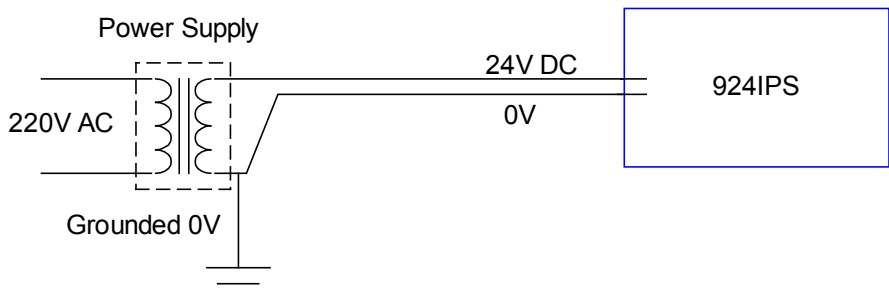

Connection to the 924IPS is via an industrial M8 4 Pin connector. With the following pin-outs:

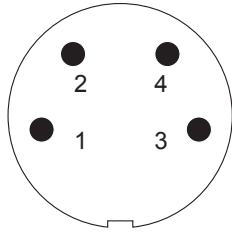

Male connector on Bar

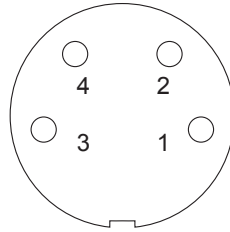

Female connector on Cable

Pin	Colour	Function Specification
1	Brown	24V (21-27V)
2	White	Clean Pin Output 0V/24V
3	Blue	0V/ Ground
4	Black	No connection

## Connection using Meech 24V DC power supply



Meech 24V DC supplies are grounded internally. It is important that the mains connection offers a ground connection. Two-pin outlets without a ground connection must not be used.

## Connection using customer's own power supply:

It is the customer's responsibility to check that the 24V power supply they will be using is grounded.

The 24V supply should be protected with a 1 Amp fuse.

## Clean Pin Alert - Remote Monitoring

Remote monitoring of the need to clean the bar is provided by the output signal on pin 2. The signal is 0V-24V suitable for direct connection to a PLC input. The output impedance of the signal is 10kΩ. The output can also be configured to power an external relay to provide volt-free contacts for other monitoring systems.

Using a BarMaster remote programmer, the output can be set to Normally Open (factory default) or Normally Closed.

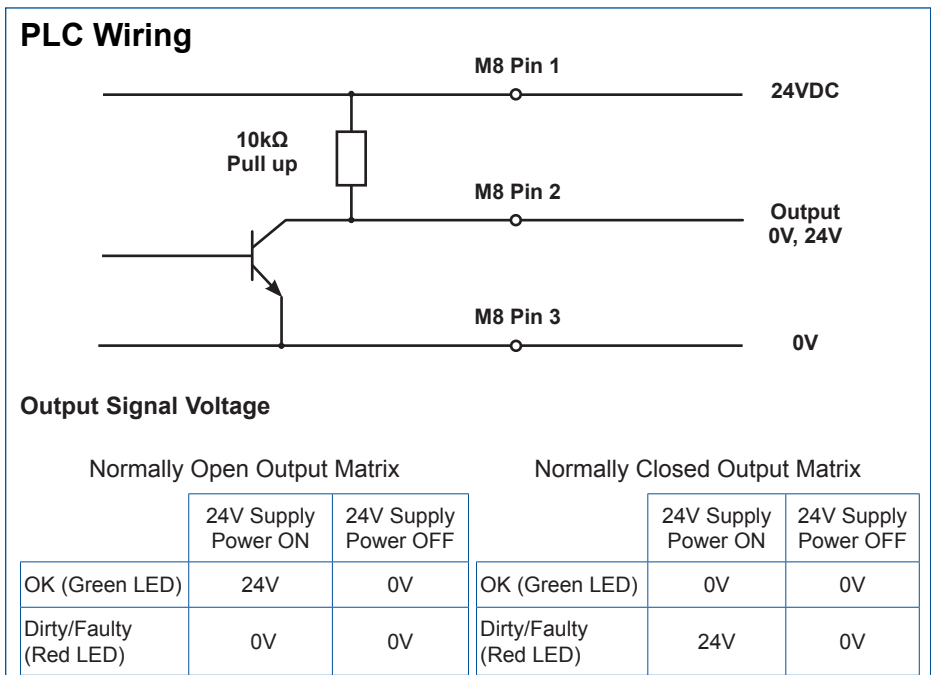

## External Relay Wiring

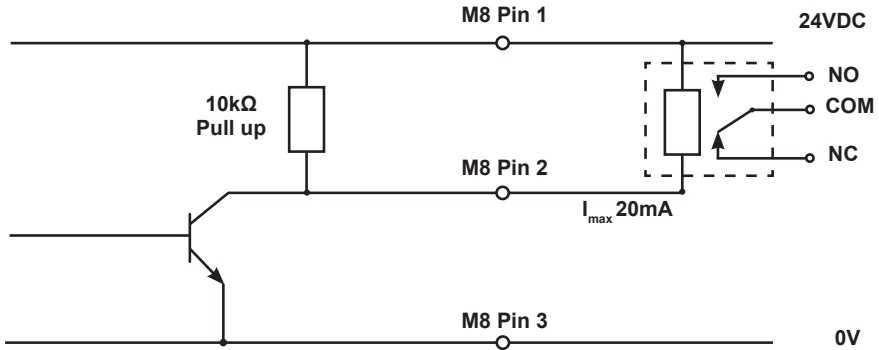

### Relay Power

Normally Open Output Matrix

	24V Supply Power ON	24V Supply Power OFF
OK (Green LED)	OFF	OFF
Dirty/Faulty (Red LED)	ON	OFF

Normally Closed Output Matrix

	24V Supply Power ON	24V Supply Power OFF
OK (Green LED)	ON	OFF
Dirty/Faulty (Red LED)	OFF	OFF

## Operation

Having connected the M8 connector to the bar, power up the 24V supply and check for a green constant LED on the bar. This indicates that the bar is running correctly with a good ion output.

### Caution

Always turn off the 24V supply before connecting or disconnecting the M8 connector. Failure to do so could result in stored charges giving a small electric shock.

## Setting the Rate

The 924IPS features a variable output frequency. The frequency that should be set depends on the ionising product and the distance to the target object.

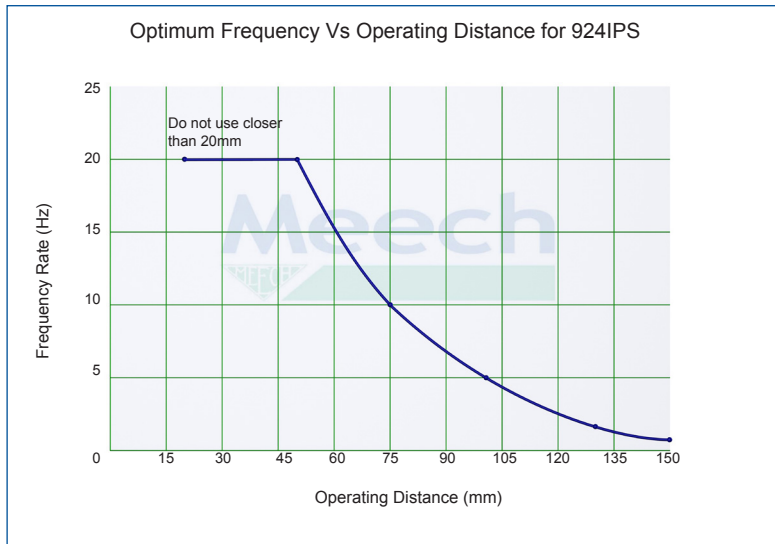

Requires optional BarMaster Remote Programmer.

## Maintenance

Ionising bars become contaminated with usage. Dirt build-up on the body of the ioniser and, particularly on the pins, will cause a drop in performance. To get the best from your bar, it should be cleaned as part of regular machine maintenance.

If regular cleaning is not carried out, the bar will detect the drop in performance and trigger the Clean Pin alert. The LED will flash red and the output signal will be activated.

Before cleaning, ensure that the equipment is switched off.

Emitter pins can be cleaned very effectively with a brush. A dry toothbrush is ideal. Make sure the central divider is also cleaned and the pin surface of the bar.



Ionising bars will need periodic wiping to clean grey deposits from the surface of the bar. A cloth moistened with a small amount of IPA or methylated spirits is recommended.



Let dry for a minute and turn back on.



# Fault Finding

To reduce the time it takes to resolve a problem with a Hyperion product, the following process must be completed before requesting assistance from Meech.

The information below shows what is required for a 924IPS bar however, the same process can be used for any of the Hyperion range of products.

## Cleaning

If regular cleaning is not carried out, the bar will detect a drop in performance and this will trigger the Clean Pin alert. The LED will flash red and the output signal will be activated.

If the LED flashes red and the bar drops in performance, follow the cleaning procedure in the **Maintenance** section on page 13.

### If cleaning does not rectify the problem:

Supplying the following information when you first contact Meech will ensure your claim is processed quickly:

1. Connect to a BarMaster and turn on the equipment
2. A readout will appear on screen and we will require the following information:

- a. Bar Code Serial Number
- b. Product Code (i.e. A924-  
(0320 = bar length))
- c. Frequency
- d. Balance
- e. Output
- f. Alarm %
- g. Ion Level %
- h. Alarm Line



3. Status of the LED (i.e. solid green, flashing red, solid red, flashing green)
4. Please provide a photo of the equipment as it is installed
5. A description and a photo or video of the problem you are experiencing
6. The action you want Meech to take e.g. repair, replace, warranty etc.

## LED Status

When the equipment powers on, the LED will show green whilst the system monitors the bars performance. If it then starts to flash red or go solid red, check the ion level with the BarMaster.

**Solid Green** indicates there is no BarMaster connected.

**Flashing Green** indicates the BarMaster has been connected.

**Flashing Red** indicates more cleaning required.

**Solid Red** indicates the ion level has dropped well below the alarm setting, prompting a serious fault warning.

Check installation for metallic objects on the emitter pins.

If the Output voltage was reduced for example from 7500V to 4000V and the Ion level was not reset. This will affect the calibration and the bar will alarm repeatedly after a short period.

Adjust the output voltage to 7500V and ensure the ion level reads 99% and the LED is green.

- a. If Ion level is 0% bar is faulty.
- b. If 10-59% with a 60% alarm setting, return to the clean bar section.

If after cleaning a 80-99% Ion level is reached, you should then reduce the output voltage to the required level. Only then can you reset the Ion Ref.

If the Ion level is well below the alarm level % the Ion output, it will shut down and a solid red LED will show.

Should the solid red LED persist, connect your BarMaster and follow the Troubleshooting section or contact your local Meech distributor.

## Warning

Do not reset the Ion Reference without cleaning the ionising bar first. Resetting the Ion Reference with a low or 0% reading will provide a green LED, but will only mask any problem with the system.

Below is the table showing the operation for a 924IPS bar and means of the LED and actions required. (Taken from the operating guide)

## Troubleshooting

Solid Green LED	Meaning	In normal operation the LED on the bar will illuminate Green. This indicates that the bar is operating correctly with good ionisation performance.
No LED	Meaning	No power to bar
	Action	Check 24V Power Supply over pins 1 and 3. (Brown and Blue wires)
Flashing Green LED	Meaning	BarMaster remote programmer is connected.
	Action	After programming, reconnect directly to the power supply to resume normal operation.
Flashing Red LED	Likely cause	Contamination causing a drop in performance.
	Action	Switch off power supply and clean as described in Maintenance section.  Turn the power on and check for green solid LED
Solid Red LED	Likely Cause	Abnormal output current detected
	Action	Check installation for metallic objects on the emitter pins.  Should the solid red LED persist, contact your Meech distributor

**The 924IPS requires a grounded 24V DC supply. The 0V line must be connected to ground. Failure to do so, will result in damage to the bar or the 24V supply and will void the warranty.**

# Repairs And Warranty

The Meech 924IPS Bar is warranted by Meech Static Eliminators Ltd. to the original purchaser against defects in material and workmanship for two years after shipment.

The 924IPS requires a grounded 24V DC supply. The 0V line **must** be connected to ground. Failure to do so, will result in damage to the bar or the 24V supply and will void the warranty.

Should any malfunction occur, please return the bar directly to Meech Static Eliminators Ltd. or your local Meech Distributor. All products returned to the factory MUST be accompanied by a return authorisation number and must be shipped prepaid. For prompt service, ship the unit to the factory with the return authorisation number shown clearly on the label. Be sure that it is well packed in a sturdy carton with shock absorbing material. Include a note stating the nature of the problem as specifically as possible, and also include instructions for returning the bar to you. We will pay one-way return shipping costs on any repairs covered under the warranty.

## UL Approval

Static elimination bar Hyperion 924IPS has been investigated by UL in accordance with the following standard(s): UL 60950-1 & CAN/CSA C22.2 No. 60950-1-07.



## CE Approval

An EC Declaration of Conformity for this product exists in respect of the Low Voltage Directive:72/23/EEC (“LVD”) & Electromagnetic Compatibility Directive: 89/336/EEC (“EMCD”)



# Technical and Construction

Dimensions (W x H)	22.1mm x 31.2mm
Maximum Length	3960mm
Operating Range	20mm – 150mm
Weight	0.5kg/metre
Construction	FR ABS
Mounting	'T' Slot with M4 x 20 studs
Emitters	Sharp titanium pins
Input Current	Max 500mA
Input Voltage	24V DC (21-27VDC)
Output Voltage	Adjustable from +/- 3kV to +/- 7.5kV Pulsed DC
Electrical Connection	4 Pole M8
Clean Pin Output Signal	24V Output resistance 10kΩ
Output Frequency	Default Setting: 20Hz Adjustable with BarMaster from 1Hz to 20Hz;
Output Balance	Default Setting: 54%:46% Pos:Neg Adjustable with BarMaster from 80:20 to 20:80 Pos:Neg
Environmental Protection	IP66
Max Ambient Temperature	60 °C

## Health and Safety

Emission of Ozone: Considerably below international standard of 0.1ppm.

# Technical Drawing

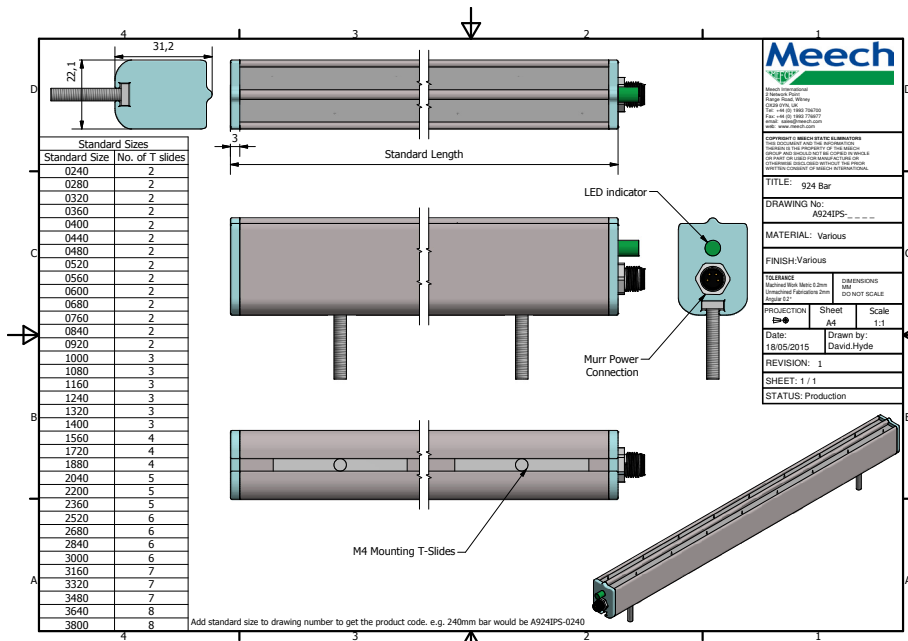

# Health and Safety

Emission of Ozone: Considerably below international standard of 0.1ppm.





#### **Meech International**

2 Network Point  
Range Road, Witney  
OX29 0YN, UK

Tel: +44 (0)1993 706700  
Fax: +44 (0)1993 776977  
email: sales@meech.com

#### **Meech Static Eliminators (Shanghai) Co. Ltd**

7G, 7F, LP Tower  
#25 Xiangfeng Road  
201103 Shanghai  
China

Tel: +86 400 820 0102  
Fax: +86 21 6405 7736  
email: china@meech.com

#### **Meech Static Eliminators USA Inc**

2915 Newpark Drive  
Norton, OH 44203  
USA

Tel: +1 330 564 2000 / 1 800 232 4210  
Fax: +1 330 564 2005  
email: info@meech.com

#### **Meech Shavotech**

29/2, Kharadi  
Off Pune-Nagar Road  
On Old Kharadi Mundhwa Road  
Pune : 411014 , Maharashtra  
India

Tel: +91 (0)703 093 8211 / +91 (0)741 000 4817  
Fax: +91 (080) 28395963  
email: india@meech.com

#### **Meech Elektrostatik SA**

Kaiserbaracke 166  
B-4780 St.Vith  
Belgium

Tel.: +49 (0)6555 3733 399  
+32 (0)80 670 204  
Fax: +32 (0)80 862 821  
email: mesa@meech.com

#### **Meech International (Singapore) Pte. Ltd.**

7 Temasek Boulevard  
12 - 07 Suntec Tower One  
Singapore  
Singapore  
038987

Tel: +65 65918859  
email: singapore@meech.com

#### **Meech CE**

Gábor László utca 2  
Budapest 1041  
Hungary

Tel: +36 1 7977039  
+36 30 2803334  
email: ce@meech.com